

# Nonparametric tests of stochastic dominance in multivariate distributions, with an application to UK data.

Ian A. Crawford\*

February 14, 2002

## Abstract

This paper make straightforward extensions to Anderson's (1996) nonparametric statistical tests of stochastic dominance criteria to multivariate distributions. These test are applied to a time series of cross-section datasets on household level total expenditure and non labour market time in the UK.

**Key Words:** Social welfare, stochastic dominance, nonparametric statistical methods.

**JEL Classification:** C14, D30.

**Acknowledgements:** I am grateful to Tony Atkinson, Martin Browning, Kevin Denny, Peter Ibbott, Ian Preston and Frank Windmeijer for helpful discussions. Financial support from the Leverhulme Trust (grant ref F/386/J) through the research programme "The Changing Distribution of Consumption, Economic Resources and the Welfare of Households" at the IFS is gratefully acknowledged. Material from the FES made available by the ONS through the ESRC Data Archive has been used by permission of the controller of HMSO. Neither the ONS nor the ESRC Data Archive bear responsibility for the analysis or the interpretation of the data reported here. The author is responsible for all errors.

---

\*Institute for Fiscal Studies and University College London. Address for correspondence: Institute for Fiscal Studies, 7 Ridgmount Street, London, WC1E 7AE. [ian\\_crawford@ifs.org.uk](mailto:ian_crawford@ifs.org.uk).

## Summary

This paper make straightforward extensions to Anderson's (1996) nonparametric statistical tests of stochastic dominance criteria to bivariate distributions. These test are applied to a time series of cross-section datasets on household level total expenditure and non labour market time in the UK.

- The paper presents stochastic dominance criteria up to third order for bivariate distributions.
- The paper presents estimators for the distributions of interest evaluated at a finite grid of points. These estimators are shown to be linear transformations of the differences in cell probabilities between two comparison distributions. This is distributed normally with mean zero and this allows the corresponding variance-covariance matrices to be derived in a simple way.
- Tests for differences in distributions are based upon nonparametric analogues of Pearson goodness-of-fit tests suggested by Anderson (1996) for univariate distributions. This is extended to bivariate distributions.
- These ideas are applied to the joint distribution of real equivalised household spending and non-labour market time using a time-series of cross-section datasets in the UK.
- It is shown that considering each of the covariates in isolation may sometimes give strongly contrasting evidence on the changes in social welfare over time and that it may therefore be important to adopt the multivariate approach. Further, it is shown that even when the null of no dominance could not be rejected in one or other marginal distribution, dominance of various order could be established with respect to the joint distribution.
- The empirical results indicate that for the population overall, social welfare increased towards the end of the period with 1995 first order dominating 1975, 1985 and 1990 indicating unanimous ranking by all functions increasing in these argument. There is also evidence of increased social welfare between 1975 and 1980 for concave functions. Results by date-of-birth cohort indicate that most of the increases in welfare were felt by the 1939 to 1950 cohort. The youngest cohort (born in 1950 and after) show some indications of reduced welfare (for concave utility functions) in the earlier years but a gain in 1995 over 1985.

## 1. Introduction

There are probably many economic and social attributes which combine to determine an individual's and a society's overall welfare. However, most of both the theoretical and applied literature on the measurement of economic and social welfare has been concerned with uni-dimensional indicators of economic status (often equivalised net or gross income). This paper makes straightforward extensions to Anderson's (1996) work on nonparametric statistical tests of stochastic dominance to allow tests of differences in social welfare based upon bivariate distributions of economic factors.

One approach to the problem of how to assess multi-dimensional distributions is to aggregate them into a single index. For example, a vector of household demands and demographic characteristics is typically aggregated using market prices as weights for the marketed goods and adjusted by an equivalence scale to reflect demographic differences such that the household's total budget multiplied by the relative equivalence scale<sup>1</sup> serves as a measure of its welfare. This is the standard way of performing real income comparisons<sup>2</sup>. Assuming that the relative equivalence scale can be calculated, this approach still only works if the relevant prices are observed, if they correctly indicate consumers' relative valuations of the goods which enter their utility function, and if they do not vary across households. Even assuming that prices are observed, one set of problems arise for instance if households are rationed (e.g. with respect to their consumption of public goods, or by involuntary unemployment). In this case, the appropriate price is not the market price but the price plus a term reflecting the dis-utility of the ration<sup>3</sup>. Another set of problems occur if the prices faced by different households vary (e.g. regionally or because of differences in productivity<sup>4</sup> or attitudes to risk). Finally, even when household utilities can be aggregated in the traditional way using market prices, it may still be desirable to allow for non-utility information such as life-span, health etc<sup>5</sup>. In each of these cases a multi-dimensional approach may be more appropriate.

The notion of stochastic dominance in multivariate distributions has been suggested in this context by Atkinson and Bourguignon (1982). Stochastic dominance criteria are essentially conditions linking differences in the empirical joint distributions of the arguments of social welfare, with the ranking of different distributions in terms of social welfare. The benefit of this approach is that it allows us to work directly with the distributions of covariates rather than requiring that they first be aggregated into some welfare indicator. The drawback is that the requirements placed on the comparison distributions such that welfare ranking can be made are typically strong but these can be weakened by placing restrictions on the class of utility functions considered. A statistical basis for this approach has been provided by Anderson (1996) who describes a simple nonparametric framework for comparing univariate distributions directly. This allows straightforward tests of stochastic dominance to be formulated. This paper extends Anderson's method to the bivariate dominance criteria set out in Atkinson and Bourguignon (1982).

The plan of the paper is as follows. Section 2 briefly sets out stochastic dominance criteria for bivariate distributions. These conditions have been described for first and second order dominance by Atkinson and Bourguignon (1982) and this paper simply

---

<sup>1</sup>Blundell and Lewbel, (1991).

<sup>2</sup>See Sen (1979a) or Deaton and Muellbauer (1980).

<sup>3</sup>Hicks (1940), Rothbath (1941), Neary and Roberts (1980)

<sup>4</sup>Ulph (1978).

<sup>5</sup>Atkinson and Bourguignon (1982).

extends the criteria to third order dominance (the highest order typically discussed in the inequality literature) for the joint distribution. Section 3 describes test of dominance for all of the functions of interest of the underlying joint distribution. These are based on Anderson's (1996) procedures which are themselves straightforward non-parametric analogues of Pearson's goodness of fit tests. Section 4 applies these tests to the joint distribution of expenditure and non labour market time in the UK using household level data budget survey data from 1975, 1980, 1985, 1990 and 1995. This contrasts the welfare inferences which might be drawn from looking solely at one or other of the univariate (marginal) distributions with those which consider the joint distribution. Section 5 draws some conclusions.

## 2. Stochastic Dominance Criteria

Suppose that social outcomes can be represented by a joint cumulative distribution function  $F(x_1, x_2)$  and a joint density function  $f(x_1, x_2)$  defined by

$$f(x_1, x_2) = \frac{\partial^2 F(x_1, x_2)}{\partial x_1 \partial x_2}.$$

If we want to be able to rank distributions in terms of social welfare then we need a way of ranking distributions drawn from the set of all possible distributions  $\mathcal{F}$  where

$$\mathcal{F} = \{F : \mathfrak{R}^2 \rightarrow [0, 1]; F \text{ nondecreasing and continuous}; F(0, 0) = 0; F(a_1, a_2) = 1\}$$

where the range space of  $x_i$  is assumed to be  $[0, a_i]$ . It is assumed that the social welfare functional is drawn from the general class  $\omega$  where

$$\omega = \left\{ W(F) \mid W(F) = \int \int \psi(x_1, x_2) dF(x_1, x_2) \right\} \quad (2.1)$$

where  $\psi(x_1^h, x_2^h) : \mathfrak{R}^2 \rightarrow \mathfrak{R}$  is the contribution to social welfare from each household. This restricts the social welfare functional to be sum-ranking but is still quite general in that this is a large set with much room for disagreement over the ranking of different social states. For example, if we define  $\psi(x_1, x_2) \equiv u(x_1, x_2)$  then we have a utilitarian social welfare function. In this case the disutility of inequality is generated by the concavity of the household utility functions. However, this formulation also covers  $\psi(x_1, x_2) \equiv \psi(u(x_1, x_2))$  where  $\psi$  is an increasing transformation of  $u$ . If the transformation is concave then this introduces concerns for inequality directly into the social welfare function. If a specific choice of  $\psi$  can be arrived at, then all social states can be ranked and the differences between them quantified. This may be very useful but the act of choosing any particular cardinal representation of social welfare will rule out other maybe equally plausible/reasonable functions which may give different rankings. Another approach is to look for conditions under which *all*  $\psi$ 's with similar canonical properties will unanimously rank social states.

Stochastic dominance criteria have been suggested as a way of ranking distributions. The ideas are parallel to those for ranking uncertain choices in decision theory and have been extended up to second order dominance to comparisons of multi-dimensional distributions by Atkinson and Bourguignon (1982). For example, suppose we wish to rank the joint distributions of  $x_1$  and  $x_2$ :  $F^A(x_1, x_2)$  and

$F^B(x_1, x_2)$ . This ranking is based upon the difference between social welfare in each distribution as defined by equation 2.1

$$\Delta W = \int_0^{a_1} \int_0^{a_2} \psi(x_1, x_2) \Delta f(x_1, x_2) dx_2 dx_1 \quad (2.2)$$

where  $\Delta f(x_1, x_2) = f^A(x_1, x_2) - f^B(x_1, x_2)$ . Following the notation in Atkinson and Bourguignon (1982) let  $F_1(x_1)$  and  $F_2(x_2)$  denote the marginal distributions of  $F(x_1, x_2)$ , let  $K(x_1, x_2) \equiv -[F(x_1, x_2) - F(x_1) - F(x_2)]$ , let  $H(x_1, x_2) = \int_0^{x_1} \int_0^{x_2} F(s, t) ds dt$ , let  $H_i(x_i) = \int_0^{x_i} F_i(s) ds$  and let  $L(x_1, x_2) = \int_0^{x_1} \int_0^{x_2} K(s, t) ds dt$ .

### 2.1. First Order Dominance

First order dominance corresponds to dominance of monotonic social welfare functions (i.e. those for which  $\psi_1, \psi_2 \geq 0$ ). This set is denoted by  $\Psi = \{\psi : \psi_i \geq 0\}$ . In the bivariate case there are two subsets according to the assumed sign of the cross-partial:  $\Psi^- = \{\psi : \psi_i \geq 0 \text{ and } \psi_{ij} \leq 0\}$  and  $\Psi^+ = \{\psi : \psi_i \geq 0 \text{ and } \psi_{ij} \geq 0\}$ . Both subsets require  $\Delta F_1(x_1), \Delta F_2(x_2) \leq 0$  (that is, first order dominance in the marginal distributions).

$$\forall x_1 \text{ and } x_2, F_1^A(x_1) - F_1^B(x_1) \leq 0 \text{ and } F_2^A(x_2) - F_2^B(x_2) \leq 0 \quad (2.3)$$

Dominance for the class  $\Psi^-$  additionally requires  $\Delta F(x_1, x_2) \leq 0$ ;

$$\forall x_1 \text{ and } x_2, F^A(x_1, x_2) - F^B(x_1, x_2) \leq 0 \quad (2.4)$$

(Hadar and Russel (1974))<sup>6</sup>.

Dominance for the class  $\Psi^+$  additionally requires  $\Delta K(x_1, x_2) \leq 0$ ;

$$\forall x_1 \text{ and } x_2, K^A(x_1, x_2) - K^B(x_1, x_2) \leq 0 \quad (2.5)$$

(Levy and Paroush (1974)).

### 2.2. Second Order Dominance

Second order dominance corresponds to a preference for mean-preserving inequality reducing changes in the distribution function. For extensions of the classes  $\Psi^-$  and  $\Psi^+$  denoted by  $\Psi^{--}$  and  $\Psi^{++}$  and defined below, both require  $\Delta H_1(x_1), \Delta H_2(x_2) \leq 0$  (that is, second order dominance in the marginal distributions).

$$\forall x_1 \text{ and } x_2, H_1^A(x_1) - H_1^B(x_1) \leq 0 \text{ and } H_2^A(x_2) - H_2^B(x_2) \leq 0 \quad (2.6)$$

The conditions for  $\Psi^{--}$  are those for  $\Psi^-$  plus  $\psi_{11}, \psi_{22} \leq 0$  and  $\psi_{112}, \psi_{122} \geq 0$ ;  $\psi_{1122} \leq 0$ . This additionally requires  $\Delta H(x_1, x_2) \leq 0$ ;

$$\forall x_1 \text{ and } x_2, H^A(x_1, x_2) - H^B(x_1, x_2) \leq 0 \quad (2.7)$$

(Atkinson and Bourguignon (1982)).

The conditions for  $\Psi^{++}$  are those for  $\Psi^+$  plus  $\psi_{11}, \psi_{22} \leq 0$  and  $\psi_{112}, \psi_{122} \leq 0$ ;  $\psi_{1122} \geq 0$ . This additionally requires  $\Delta L(x_1, x_2) \leq 0$ ;

$$\forall x_1 \text{ and } x_2, L^A(x_1, x_2) - L^B(x_1, x_2) \leq 0 \quad (2.8)$$

(Atkinson and Bourguignon (1982)).

<sup>6</sup> $\Delta F_1(x_1) \leq 0$  and  $\Delta F_2(x_2) \leq 0$  are both implied by  $\Delta F(x_1, x_2) \leq 0$ .

### 2.3. Third Order Dominance

Third order dominance corresponds to a preference for inequality reducing changes in the lower end of the distribution function. The class of  $\psi$  functions considered here are straightforward extensions of  $\Psi^{--}$  and  $\Psi^{++}$ . These are denoted by  $\Psi^{---}$  and  $\Psi^{+++}$  and are defined below. First let  $J(x_1, x_2) = \int_0^{x_1} \int_0^{x_2} H(s, t) dsdt$ , let  $J_i(x_i) = \int_0^{x_i} H_i(s) ds$  and let  $M(x_1, x_2) = \int_0^{x_1} \int_0^{x_2} L(s, t) dsdt$ . For  $\Psi^{---}$  and  $\Psi^{+++}$  both require  $\Delta J_1(x_1), \Delta J_2(x_2) \leq 0$  (that is, third order dominance in the marginal distributions).

$$\forall x_1 \text{ and } x_2, J_1^A(x_1) - J_1^B(x_1) \leq 0 \text{ and } J_2^A(x_2) - J_2^B(x_2) \leq 0 \quad (2.9)$$

The conditions for  $\Psi^{---}$  are those for  $\Psi^{--}$  plus  $\psi_{1112}, \psi_{1122} \geq 0$  and  $\psi_{11122}, \psi_{11222} \geq 0$ ;  $\psi_{111222} \leq 0$ . This additionally requires  $\Delta J(x_1, x_2) \leq 0$ :

$$\forall x_1 \text{ and } x_2, J^A(x_1, x_2) - J^B(x_1, x_2) \leq 0; \quad (2.10)$$

The conditions for  $\Psi^{+++}$  are those for  $\Psi^{++}$  plus  $\psi_{1112}, \psi_{1122} \geq 0$  and  $\psi_{11122}, \psi_{11222} \geq 0$ ;  $\psi_{111222} \geq 0$ . This additionally requires  $\Delta M(x_1, x_2) \leq 0$

$$\forall x_1 \text{ and } x_2, M^A(x_1, x_2) - M^B(x_1, x_2) \leq 0 \quad (2.11)$$

Given these conditions linking social welfare rankings to characteristics of the underlying distributions, the general approach is to construct estimates of  $\Delta F_i(\cdot)$ ,  $\Delta F(\cdot)$ ,  $\Delta K(\cdot)$ ,  $\Delta H_i(\cdot)$ ,  $\Delta H(\cdot)$ ,  $\Delta L(\cdot)$ ,  $\Delta J_i(\cdot)$ ,  $\Delta J(\cdot)$  and  $\Delta M(\cdot)$ , and to check conditions (2.3) to (2.11) to see if stochastic dominance can be established and of what order, and to check the class of social welfare functions for which such dominance is established.

## 3. Statistical tests of Stochastic Dominance

Let the joint rangespace of  $x_1$  and  $x_2$  be partitioned into  $s$  and  $t$  mutually exclusive and exhaustive categories respectively<sup>7</sup>. Denote by  $n_{ij}$  the number of observations falling into the  $ij$ th category and denote the total number of observations by  $n$ . The probability of falling into the  $ij$ th cell is

$$p_{ij} = \text{Prob} \left\{ \mathbf{x} \in \{x_1^{i-1}, x_1^i\} \cap \{x_2^{j-1}, x_2^j\} \right\}$$

where these probabilities are defined by the unknown distribution  $F(x_1, x_2)$  (i.e.  $p_{ij} = F(x_i, x_j) - F(x_i, x_{j-1}) - F(x_{i-1}, x_j) + F(x_{i-1}, x_{j-1})$ ).

Let  $\hat{\mathbf{n}}$  be the  $(s \times t)$  matrix of empirical cell counts. This empirical frequency matrix is asymptotically distributed  $N(\boldsymbol{\mu}, \boldsymbol{\Omega})$  (Kendall and Stewart (1979)) where

$$\frac{1}{n} \boldsymbol{\mu} = \begin{bmatrix} p_{11} & p_{12} & \dots & p_{1t} \\ p_{21} & p_{22} & \dots & p_{2t} \\ \vdots & \vdots & \ddots & \vdots \\ p_{s1} & p_{s2} & \dots & p_{st} \end{bmatrix}$$

<sup>7</sup>There are two ways to proceed: either choose partition points and allow the cell frequencies to be determined by the unknown distribution, or choose the cell frequencies and allow the intervals between the partition points to be determined.

$$\frac{1}{n}\boldsymbol{\Omega} = \begin{bmatrix} p_{11}(1-p_{11}) & -p_{11}p_{12} & \cdots & -p_{11}p_{st} \\ -p_{12}p_{11} & p_{12}(1-p_{12}) & \cdots & -p_{12}p_{st} \\ \vdots & \vdots & \ddots & \vdots \\ -p_{st}p_{11} & -p_{st}p_{12} & \cdots & p_{st}(1-p_{st}) \end{bmatrix}.$$

Now suppose we wish to compare two distributions. Let the sample sizes be  $n^A$  and  $n^B$ . Let the matrices of empirical frequencies be  $\widehat{\mathbf{n}}^A$  and  $\widehat{\mathbf{n}}^B$  and the estimated cell probabilities be  $\widehat{\mathbf{p}}^A = (n^A)^{-1}\widehat{\mathbf{n}}^A$  and  $\widehat{\mathbf{p}}^B = (n^B)^{-1}\widehat{\mathbf{n}}^B$ . Denote the difference between the estimated cell probabilities by

$$\widehat{\mathbf{v}} = (\widehat{\mathbf{p}}^A - \widehat{\mathbf{p}}^B).$$

Under the null assumption of common distributions then

$$\widehat{\mathbf{v}} \stackrel{a}{\sim} N(\mathbf{0}, m\boldsymbol{\Omega})$$

where

$$m = \frac{n^A + n^B}{n^A n^B}.$$

If the objects of interest i.e.  $\Delta F_i(\cdot)$ ,  $\Delta F(\cdot)$ ,  $\Delta K(\cdot)$ ,  $\Delta H_i(\cdot)$ ,  $\Delta H(\cdot)$ ,  $\Delta L(\cdot)$ ,  $\Delta J_i(\cdot)$ ,  $\Delta J(\cdot)$  and  $\Delta M(\cdot)$  can be written as linear transformations of the (normally distributed) differences in cell probabilities, then nonparametric tests (analogous to Pearson goodness of fit tests but in which  $F(\cdot)$  need not be specified) of stochastic dominance can be derived in a straightforward manner. This is shown in Anderson (1996) who then provides a framework for statistical tests of dominance in univariate distributions up to third order. Ibbott (1998) describes a test for first order dominance in bivariate distributions. The following describes tests for first, second and third order dominance in bivariate distributions (the treatment of first order dominance is different to that in Ibbott (1998)).

Let  $\mathbf{L}_r$  be a  $r$  dimension lower triangular matrix of ones, let  $\mathbf{1}_r$  be a vector of ones of length  $r$ , let  $\mathbf{W}_r$  be an  $(r \times (r+1))$  matrix of zeros and ones such that

$$\mathbf{W}_r = \begin{bmatrix} 1 & 1 & 0 & \cdots & 0 & 0 \\ 0 & 1 & 1 & \cdots & 0 & 0 \\ \vdots & \vdots & \vdots & \vdots & \vdots & \vdots \\ 0 & 0 & 0 & \cdots & 1 & 1 \end{bmatrix},$$

let  $\mathbf{T}_r$  be an  $((r+1) \times r)$  matrix consisting of an  $(1 \times r)$  row vector of zeros vertically concatenated above an  $\mathbf{L}_r$ . Let  $\boldsymbol{\delta}_1$  be a  $(1 \times s)$  row vector of interval widths defined on the partition of  $x_1$ , and let  $\boldsymbol{\delta}_2$  be a  $(1 \times t)$  row vector of interval widths defined on the partition of  $x_2$ .

### 3.1. First Order Dominance

The estimates of  $\Delta F_1(x_1)$  and  $\Delta F_2(x_2)$  at the partition points are given by

$$\begin{aligned} \widehat{\Delta \mathbf{F}}_1 &= \mathbf{L}_s \widehat{\mathbf{v}} \mathbf{1}_t \\ \widehat{\Delta \mathbf{F}}_2 &= \mathbf{1}'_s \widehat{\mathbf{v}} \mathbf{L}'_t \end{aligned} \quad (3.1)$$

and  $\Delta F(x_1, x_2)$  can be estimated at the partition points by

$$\widehat{\Delta \mathbf{F}} = \mathbf{L}_s \widehat{\mathbf{v}} \mathbf{L}'_t. \quad (3.2)$$

Similarly  $\Delta K(x_1, x_2)$  can be estimated at the partition points by

$$\widehat{\Delta \mathbf{K}} = - \begin{bmatrix} \mathbf{I}_s \vdots - \mathbf{I}_s \vdots - \mathbf{I}_s \end{bmatrix} \begin{bmatrix} \mathbf{L}_s \widehat{\mathbf{v}} \mathbf{L}'_t \\ \boldsymbol{\nu}_s \boldsymbol{\nu}'_s \widehat{\mathbf{v}} \mathbf{L}'_t \\ \mathbf{L}_s \widehat{\mathbf{v}} \boldsymbol{\nu}_t \boldsymbol{\nu}'_t \end{bmatrix}. \quad (3.3)$$

### 3.2. Second Order Dominance

Using the trapezoidal/linear interpolation rule for approximating integrals<sup>8</sup>, approximations of  $\Delta H_1(x_1)$  and  $\Delta H_2(x_2)$  can be estimated at the partition points by<sup>9</sup>

$$\begin{aligned} \widehat{\Delta \mathbf{H}}_1 &= \mathbf{L}_s (0.5\boldsymbol{\delta}_1 \odot \mathbf{I}_s) \mathbf{W}_s \mathbf{T}_s \mathbf{L}_s \widehat{\mathbf{v}} \boldsymbol{\nu}_t \\ \widehat{\Delta \mathbf{H}}_2 &= \boldsymbol{\nu}'_s \widehat{\mathbf{v}} \mathbf{L}'_t \mathbf{T}'_t \mathbf{W}'_t (0.5\boldsymbol{\delta}_2 \odot \mathbf{I}_t) \mathbf{L}'_t \end{aligned} \quad (3.4)$$

and an approximation of  $\Delta H(x_1, x_2)$  can be estimated at the partition points by

$$\widehat{\Delta \mathbf{H}} = \mathbf{L}_s (0.5\boldsymbol{\delta}_1 \odot \mathbf{I}_s) \mathbf{W}_s \mathbf{T}_s \mathbf{L}_s \widehat{\mathbf{v}} \mathbf{L}'_t \mathbf{T}'_t \mathbf{W}'_t (0.5\boldsymbol{\delta}_2 \odot \mathbf{I}_t) \mathbf{L}'_t. \quad (3.5)$$

Similarly an approximation of  $\Delta L(x_1, x_2)$  can be estimated at the partition points using

$$\begin{aligned} \widehat{\Delta \mathbf{L}} &= \mathbf{L}_s (0.5\boldsymbol{\delta}_1 \odot \mathbf{I}_s) \mathbf{W}_s \mathbf{T}_s \left( - \begin{bmatrix} \mathbf{I}_s \vdots - \mathbf{I}_s \vdots - \mathbf{I}_s \end{bmatrix} \right) \\ &\quad \begin{bmatrix} \mathbf{L}_s \widehat{\mathbf{v}} \mathbf{L}'_t \\ \boldsymbol{\nu}_s \boldsymbol{\nu}'_s \widehat{\mathbf{v}} \mathbf{L}'_t \\ \mathbf{L}_s \widehat{\mathbf{v}} \boldsymbol{\nu}_t \boldsymbol{\nu}'_t \end{bmatrix} \mathbf{T}'_t \mathbf{W}'_t (0.5\boldsymbol{\delta}_2 \odot \mathbf{I}_t) \mathbf{L}'_t. \end{aligned} \quad (3.6)$$

### 3.3. Third Order Dominance

Approximations of  $\Delta J_1(x_1)$  and  $\Delta J_2(x_2)$  can be estimated at the partition points by

$$\begin{aligned} \widehat{\Delta \mathbf{J}}_1 &= \mathbf{L}_s (0.5\boldsymbol{\delta}_1 \odot \mathbf{I}_s) \mathbf{W}_s \mathbf{T}_s \mathbf{L}_s (0.5\boldsymbol{\delta}_1 \odot \mathbf{I}_s) \mathbf{W}_s \mathbf{T}_s \mathbf{L}_s \widehat{\mathbf{v}} \boldsymbol{\nu}_t \\ \widehat{\Delta \mathbf{J}}_2 &= \boldsymbol{\nu}'_s \widehat{\mathbf{v}} \mathbf{L}'_t \mathbf{T}'_t \mathbf{W}'_t (0.5\boldsymbol{\delta}_2 \odot \mathbf{I}_t) \mathbf{L}'_t \mathbf{T}'_t \mathbf{W}'_t (0.5\boldsymbol{\delta}_2 \odot \mathbf{I}_t) \mathbf{L}'_t \end{aligned} \quad (3.7)$$

and an approximation of  $\Delta J(x_1, x_2)$  can be estimated at the partition points by

$$\begin{aligned} \widehat{\Delta \mathbf{J}} &= \mathbf{L}_s (0.5\boldsymbol{\delta}_1 \odot \mathbf{I}_s) \mathbf{W}_s \mathbf{T}_s \mathbf{L}_s (0.5\boldsymbol{\delta}_1 \odot \mathbf{I}_s) \mathbf{W}_s \mathbf{T}_s \mathbf{L}_s \widehat{\mathbf{v}} \\ &\quad \mathbf{L}'_t \mathbf{T}'_t \mathbf{W}'_t (0.5\boldsymbol{\delta}_2 \odot \mathbf{I}_t) \mathbf{L}'_t \mathbf{T}'_t \mathbf{W}'_t (0.5\boldsymbol{\delta}_2 \odot \mathbf{I}_t) \mathbf{L}'_t. \end{aligned} \quad (3.8)$$

Similarly an approximation of  $\Delta M(x_1, x_2)$  can be estimated at the partition points using

$$\begin{aligned} \widehat{\Delta \mathbf{M}} &= \mathbf{L}_s (0.5\boldsymbol{\delta}_1 \odot \mathbf{I}_s) \mathbf{W}_s \mathbf{T}_s \mathbf{L}_s (0.5\boldsymbol{\delta}_1 \odot \mathbf{I}_s) \mathbf{W}_s \mathbf{T}_s \left( - \begin{bmatrix} \mathbf{I}_s \vdots - \mathbf{I}_s \vdots - \mathbf{I}_s \end{bmatrix} \right) \\ &\quad \begin{bmatrix} \mathbf{L}_s \widehat{\mathbf{v}} \mathbf{L}'_t \\ \boldsymbol{\nu}_s \boldsymbol{\nu}'_s \widehat{\mathbf{v}} \mathbf{L}'_t \\ \mathbf{L}_s \widehat{\mathbf{v}} \boldsymbol{\nu}_t \boldsymbol{\nu}'_t \end{bmatrix} \mathbf{T}'_t \mathbf{W}'_t (0.5\boldsymbol{\delta}_2 \odot \mathbf{I}_t) \mathbf{L}'_t \mathbf{T}'_t \mathbf{W}'_t (0.5\boldsymbol{\delta}_2 \odot \mathbf{I}_t) \mathbf{L}'_t. \end{aligned} \quad (3.9)$$

<sup>8</sup>The quality of the approximation depends on the shape of the unknown cumulative distribution function and the location and number of nodes. However, locating partitions at equal quantile points will improve the approximation by linearising the CDF.

<sup>9</sup>Note that  $\odot$  denotes the Hadamard product (element-by-element multiplication) operation on two matrices of the same dimensions.

Since all of these estimators are linear with the general form:

$$\widehat{\Delta\mathbf{Y}} = \mathbf{A}\widehat{\mathbf{v}}\mathbf{B}$$

where  $\widehat{\mathbf{v}} \stackrel{a}{\sim} N(\mathbf{0}, m\boldsymbol{\Omega})$ , it is reasonably straightforward to construct estimates of the variance-covariance matrix of  $\widehat{\Delta\mathbf{Y}}$  using the fact that  $\widehat{\mathbf{v}}$  is mean-zero and so

$$\text{Var}(\mathbf{A}\widehat{\mathbf{v}}\mathbf{B}) = E((\text{vec}(\mathbf{A}\widehat{\mathbf{v}}\mathbf{B}))(\text{vec}(\mathbf{A}\widehat{\mathbf{v}}\mathbf{B}))')$$

and can be written as<sup>10</sup>

$$\text{Var}(\mathbf{A}\widehat{\mathbf{v}}\mathbf{B}) = (\mathbf{B}' \otimes \mathbf{A}) \text{Var}(\widehat{\mathbf{v}}) (\mathbf{B} \otimes \mathbf{A}')$$

For example

$$\text{Var}(\widehat{\Delta\mathbf{F}}) = \mathbf{L}_t \otimes \mathbf{L}_s m\boldsymbol{\Omega} \mathbf{L}_t' \otimes \mathbf{L}_s'$$

Forming these estimates and dividing through element-by-element by their standard errors forms the basis of a test of the null (common distribution) and alternative (dominance) hypotheses given in table (3.1).

Table 3.1: Bivariate dominance criteria, null and alternative hypotheses.

Null	Alternative	Class of $\Psi$
<i>1st Order dominance</i>		
$H_0 : \Delta F_i(\cdot), \Delta F(\cdot) = 0$	$H_{1F} : \Delta F_i(\cdot), \Delta F(\cdot) \leq 0$	$\Psi^-$
$H_0 : \Delta F_i(\cdot), \Delta K(\cdot) = 0$	$H_{1K} : \Delta F_i(\cdot), \Delta K(\cdot) \leq 0$	$\Psi^+$
$H_0 : \Delta F_i(\cdot), \Delta F(\cdot), \Delta K(\cdot) = 0$	$H_1 : H_{1F}$ and $H_{1K}$	$\Psi^- \cup \Psi^+$
<i>2nd Order dominance</i>		
$H_0 : \Delta H_i(\cdot), \Delta H(\cdot) = 0$	$H_{2H} : \Delta H_i(\cdot), \Delta H(\cdot) \leq 0$	$\Psi^{--}$
$H_0 : \Delta H_i(\cdot), \Delta L(\cdot) = 0$	$H_{2L} : \Delta H_i(\cdot), \Delta L(\cdot) \leq 0$	$\Psi^{++}$
$H_0 : \Delta H_i(\cdot), \Delta H(\cdot), \Delta L(\cdot) = 0$	$H_2 : H_{2H}$ and $H_{2L}$	$\Psi^{--} \cup \Psi^{++}$
<i>3rd Order dominance</i>		
$H_0 : \Delta J_i(\cdot), \Delta J(\cdot) = 0$	$H_{3J} : \Delta J_i(\cdot), \Delta J(\cdot) \leq 0$	$\Psi^{---}$
$H_0 : \Delta J_i(\cdot), \Delta M(\cdot) = 0$	$H_{3M} : \Delta J_i(\cdot), \Delta M(\cdot) \leq 0$	$\Psi^{+++}$
$H_0 : \Delta J_i(\cdot), \Delta J(\cdot) = 0, \Delta M(\cdot) = 0$	$H_3 : H_{3J}$ and $H_{3M}$	$\Psi^{---} \cup \Psi^{+++}$

For example, using the convention adopted in Anderson (1996) and in Bishop, Chakraborti and Thistle (1989) the hypothesis test of  $H_0 : \Delta F_i(\cdot), \Delta F(\cdot) = 0$  versus  $H_{1F} : \Delta F_i(\cdot), \Delta F(\cdot) \leq 0$  is essentially that

$$\forall x_1 \text{ and } x_2, \quad F^A(x_1, x_2) - F^B(x_1, x_2) \leq 0$$

<sup>10</sup>Magnus and Neudecker (1988)

and

$$\exists x_1 \text{ and } x_2, \quad F^A(x_1, x_2) - F^B(x_1, x_2) < 0$$

i.e. no element of the matrix  $\widehat{\Delta \mathbf{F}}$  is significantly greater than zero, and that at least one element is significantly less than zero<sup>11</sup>.

Note that the marginal distributions  $(\widehat{\Delta \mathbf{F}}_1, \widehat{\Delta \mathbf{F}}_2, \widehat{\Delta \mathbf{H}}_1, \widehat{\Delta \mathbf{H}}_2, \widehat{\Delta \mathbf{J}}_1, \widehat{\Delta \mathbf{J}}_2)$ , and the test statistics based on them, correspond exactly to Anderson's tests of first, second and third order dominance in the univariate (marginal) distributions. The null and alternative hypotheses for dominance in the univariate distributions are given in table (3.2). The relevant classes of univariate functions (denoted by  $\Psi$ ) are  $\Psi$  for all functions which increase monotonically ( $\Psi = \{\psi : \psi_i \geq 0\}$ ) with respect to their single argument,  $\Psi^-$  which is the subset of  $\Psi$  with diminishing first derivatives ( $\Psi^- = \{\psi : \psi_i \geq 0, \psi_{ii} \leq 0\}$ ) and  $\Psi^{--}$  which is the subset of  $\Psi^-$  with negative third derivatives ( $\Psi^{--} = \{\psi : \psi_i \geq 0, \psi_{ii} \leq 0, \psi_{iii} \leq 0\}$ ).

Table 3.2: Univariate dominance criteria, null and alternative hypotheses.

Null	Alternative	Class of $\Psi$
<i>1st Order dominance</i>		
$h_0 : \Delta F_i(\cdot) = 0$	$h_1 : \Delta F_i(\cdot) \leq 0$	$\Psi$
<i>2nd Order dominance</i>		
$h_0 : \Delta H_i(\cdot)$	$h_2 : \Delta H_i(\cdot) \leq 0$	$\Psi^-$
<i>3rd Order dominance</i>		
$h_0 : \Delta J_i(\cdot)$	$h_3 : \Delta J_i(\cdot) \leq 0$	$\Psi^{--}$

Whilst each element of these matrices can be tested using pointwise procedures, the overall test for the whole matrix will, in each case, involve multiple comparisons of differences in means. Under the null hypothesis (no dominance/common distributions) this involves the use of the critical values from the studentised maximum modulus (SMM) distribution (Stoline and Ury (1979)) with degrees of freedom equal to the number of cells. Note that these tests are symmetric. For example if we find that we cannot reject  $H_0$  in favour of  $H_{1F}$  then, while we cannot establish first order dominance (for  $\Psi^-$ ) of  $F^A$  over  $F^B$ , at the same time we know that we will be able to reject the null in favour of first order dominance of  $F^B$  over  $F^A$  for the same general class of functions.

<sup>11</sup>In principle there is a further alternative hypothesis, one of indeterminacy. For example in the case of first order dominance

$$H_{1F} : \Delta F_i(\cdot), \Delta F(\cdot) \not\leq \wedge \not\geq 0 \Rightarrow \text{indeterminate}$$

For  $H_{1F}$  not to be rejected requires that there exist both significantly positive and significantly negative elements of  $\widehat{\Delta \mathbf{F}}$  (Anderson (1996)).

## 4. Empirical Application

This section applies the ideas outlined above to the analysis of dominance in the joint distribution of household total expenditure and non labour market time<sup>12</sup>. Stochastic dominance criteria may be a fruitful way of approaching welfare measurement defined over these arguments because of the particular problems involved in determining the price of non-market time when this may depend on unobserved cross-sectional productivity differences, or the incidence of cyclical or sector-specific involuntary unemployment.

Goodman and Webb (1995) have shown that inequality in real equivalised total household expenditure grew over the 1980's and levelled off in the early 1990's. This increase in inequality was less marked than the increase in income inequality over the same period. They also show that whilst real incomes amongst the poorest tenth of the population were flat over the period, real expenditure amongst this group grew. Gregg and Wadsworth (1996) show that, over roughly the same period, whilst employment in general moved cyclically, the number of households with zero hours work rose steeply in the early 1980's but the employment growth (in large part an increase in part-time work) which occurred subsequently was largely confined to households which already had positive hours of work. This resulted, by the end of the period, in a situation in which there were many more multi-worker households and roughly twice as many households with no workers.

In this section each household's contribution to social welfare is defined to be a time separable and increasing function of equivalised current real expenditure<sup>13</sup> ( $\tilde{x}$ ) and a decreasing function of current hours of work ( $t$ ), that is<sup>14</sup>

$$\psi^h = \psi(\tilde{x}^h, -t^h)$$

is the contribution (or the utility function if  $\psi(\tilde{x}^h, -t^h) = u(\tilde{x}^h, -t^h)$ ) of the  $h$ th household, where  $\psi_x^h \geq 0$  and  $\psi_{-t}^h \geq 0$  or equivalently  $\psi_t^h \leq 0$ . The assumption of time separability means that a comparison of social welfare between periods depends only upon difference in the within-period distributions. The arguments of social welfare are chosen to be observable analogues of consumption and leisure although both are far from perfect proxies. If first order dominance can be established then there is no need to specify the signs of second derivatives and cross partials. If first order dominance cannot be established, then the tests of second order dominance will concentrate on functions drawn from  $\Psi^{--}$  and  $\Psi^{++}$  (i.e. concave functions). If second order dominance cannot be established further restrictions are placed on the set of admissible functions and third order dominance is examined.

### 4.1. Data

The data are from the Family Expenditure Survey (FES) for the years 1975, 1980, 1985, 1990 and 1995. The FES is an annual random cross section survey of around

---

<sup>12</sup>Ibbott (1998) looks at first order dominance criteria for this joint distribution amongst Canadian households.

<sup>13</sup>Note that this includes any expenditures related to the fixed and variable costs of being in work which (all other things being equal) may not be welfare increasing.

<sup>14</sup>Household expenditures are normalised by the McClement's equivalence scale and deflated by a common Törnqvist price index with weights taken from the all items Retail Prices Index (1997=1). Hours of work have not been normalised on the basis that the marginal (dis)utility of an hour's work is not affected by typical normalisation schemes where leisure is measured by the household's total time endowment less the number of hours worked.

7,000 households (this represents a response rate of around 70% for most of the period). The FES records data on household structure, employment, income and the spending over the course of a two week diary period. In the FES the information is aggregated to the household level and averaged across the two week period to give weekly expenditure figures for over 300 different goods and services. In what follows the data on total expenditure is defined in the FES as total (weekly) household expenditure plus the imputed value of free school milk and school meals. This is then deflated to 1999 values and equivalised as described above. Hours of work are total usual weekly hours excluding breaks and overtime for the household.

Figure 4.1: Estimated cell probabilities and distribution function, 1975

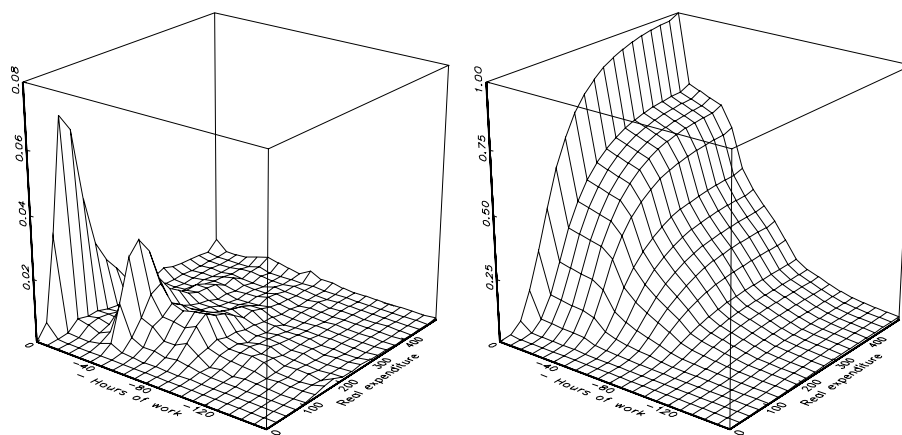
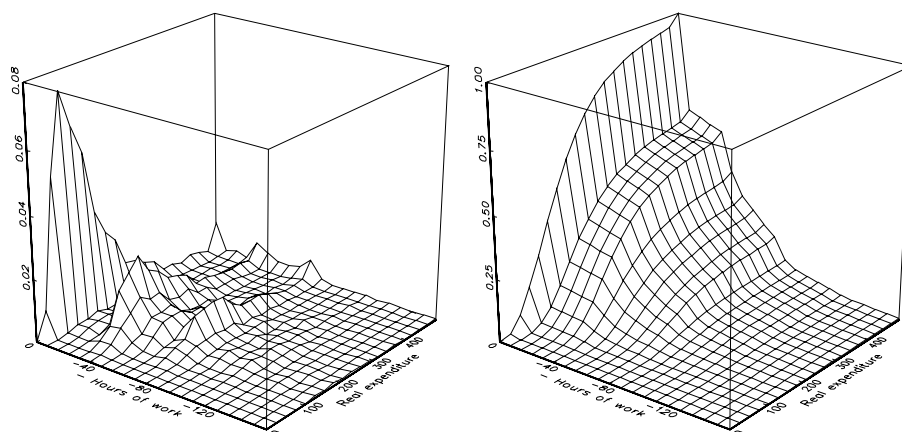

Figure 4.2: Estimated cell probabilities and distribution function, 1985.



Figures 4.1, 4.2 and 4.3 illustrate  $\hat{\mathbf{p}}$ , and  $\hat{\mathbf{F}}$  for 1975, 1985 and 1995<sup>15</sup>. These

<sup>15</sup>Similar figures for the other years studied are available (grudgingly) from the author.

Figure 4.3: Estimated cell probabilities and distribution function, 1995.

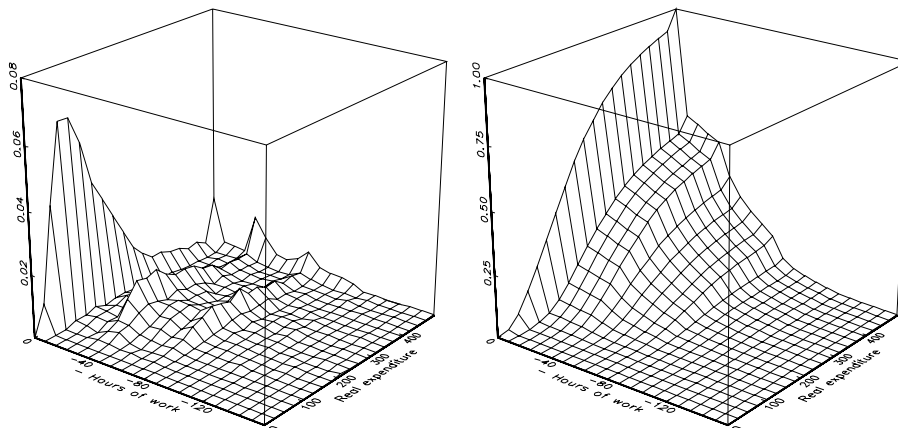

figures use all of the available data from each year. All the years indicate mass points in the non-market time distribution at 0, -40 and -80 hours roughly corresponding to zero hours work and to full-time work for one and two adults in a household. However these mass points grow less pronounced over time with increased frequency of observations elsewhere indicating the growth in part-time work. In the real (equivalised) expenditure dimension there is evidence of an increased number of observations in the upper tail over time.

## 4.2. Results

This section reports the results of tests of dominance in the joint distribution of real equivalised total household expenditure, and non labour market time for all for the years considered. The joint distribution is partitioned into  $10 \times 10$  cells with the partitions in each dimension placed at the nine decile points. The tests reported below are at 95% for both univariate and bivariate distributions (the critical values from the SMM distribution are 2.8 for the univariate results and 3.47 for the bivariate results<sup>16</sup>). The aim is to contrast the different welfare implications drawn when considering each of the univariate distributions in isolation, with the those which focus on the joint distribution.

### 4.2.1. Full sample results

Table 4.1 gives descriptive statistics for the covariates for the entire sample. Mean real expenditure grew year-on-year over the period, as did inequality in real spending as measured by its variance also grew up until 1990. However, between 1990 and 1995 the variance of real expenditure fell. Mean non labour market time increased every year and its variance fell.

The first two blocks of table 4.2 reports the results of the dominance tests in each of the univariate distributions. The entries indicate the dominance hypothesis

<sup>16</sup>Stoline and Ury (1979).

which rejects the relevant null for the row-year over the column-year. For example  $h_1$  in the row for 1980 and the column for 1975 in the first block indicates that the null of common distributions is rejected in favour of dominance of 1980 over 1975 for all  $\psi(\tilde{x}^h)$  in  $\Psi$ . In the case of non labour market time later years always first order dominate earlier ones, perhaps unsurprisingly given data on increase means and reduced variances over the period. The univariate results for real expenditure follow a roughly similar pattern with first order dominance established for 1980 over 1975, for 1990 over 1985 and for 1995 over all years except for 1980.

The bivariate results for these data are reported in the third block in table 4.2 and are similar to those in the univariate table. Indeed they should be as rejection of univariate dominance in the marginal distributions would also reject dominance in the joint distribution. First order dominance is established for 1990 over 1985 and for 1995 over all years except for 1980. However, 1980, which first order dominated 1975 with respect to both marginal distributions only first order dominates 1975 for functions within the class  $\Psi^+$  (positive cross partials). Second order dominance, however, is established for  $\Psi^-$  and hence for  $\Psi^{++} \cup \Psi^{--}$ .

Table 4.1: Descriptive statistics, all households.

	$\tilde{x}^h$				$-t^h$				n
	Mean	Std.Dev	Min	Max	Mean	Std.Dev	Min	Max	
75	197.22	128.15	29.25	3365.54	-45.12	38.25	-270	0	7203
80	207.05	129.00	21.10	2793.25	-41.43	37.06	-240	0	6944
85	220.36	155.49	10.67	2912.98	-35.62	36.22	-276	0	7012
90	246.47	198.88	20.12	5287.11	-34.38	34.95	-218	0	7046
95	261.24	183.75	26.78	3514.31	-31.79	34.01	-244	0	6759

Table 4.2: Dominance results, all households.

	$\psi(\tilde{x}^h)$					$\psi(-t^h)$					$\psi(\tilde{x}^h, -t^h)$				
	75	80	85	90	95	75	80	85	90	95	75	80	85	90	95
75															
80	$h_1$					$h_1$					$H_{1(K)}H_{2(H)}$				
85						$h_1$	$h_1$								
90			$h_1$			$h_1$	$h_1$	$h_1$						$H_1$	
95	$h_1$		$h_1$	$h_1$		$h_1$	$h_1$	$h_1$	$h_1$		$H_1$		$H_1$	$H_1$	

#### 4.2.2. Date-of-birth cohort results

In the section the data are split by date-of-birth cohort<sup>17</sup>. The first set of results are for the pre 1930 cohort. The youngest of these households would have been 46 in 1975 and 76 by 1995. The number of observations in this cohort drops from 3,539 in 1975 to 1,456 in 1995 partly through mortality and partly because of higher non-response

<sup>17</sup>The split is based upon mean date of birth for all adults in the household.

rates in the FES for older households and because people in retirement homes are not surveyed. The mean age in the cohort will therefore be dropping over time.

Table 4.3: Descriptive statistics, households with mean adult d.o.b pre 1930.

	$\tilde{x}^h$				$-t^h$				n
	Mean	Std.Dev	Min	Max	Mean	Std.Dev	Min	Max	
75	180.60	135.98	29.25	3365.54	-27.44	32.35	-164	0	3539
80	182.66	132.84	21.10	2793.25	-18.79	26.29	-168	0	2892
85	184.75	146.76	34.61	2912.98	-8.84	18.50	-115	0	2487
90	189.74	172.66	20.12	2036.30	-3.92	12.32	-112	0	2057
95	180.66	155.12	26.78	3514.31	-1.32	6.55	-83	0	1456

Table 4.3 reports descriptive statistics and shows increase real spending up until 1990 followed by a drop, possibly related to retirement in this cohort. Real expenditure inequality measured by its variance falls between 1975 and 1980 but rises afterwards until 1990. In the 1995 the variance of spending drops. Non market time in this cohort increases every year with mean hours of work reaching very low levels by 1995. Its variance falls year-on-year.

Table 4.4: Dominance results, households with mean adult d.o.b. pre 1930.

	$\psi(\tilde{x}^h)$					$\psi(-t^h)$					$\psi(\tilde{x}^h, -t^h)$				
	75	80	85	90	95	75	80	85	90	95	75	80	85	90	95
75	$h_1$	$h_1$	$h_1$	$h_1$											
80		$h_1$	$h_1$	$h_1$		$h_1$					$H_2$				
85			$h_1$			$h_1$	$h_1$								
90						$h_1$	$h_1$	$h_1$							
95			$h_3$	$h_2$		$h_1$	$h_1$	$h_1$	$h_1$						$H_2$

The dominance results are summarised in table 4.4. The univariate results indicate that earlier years tend to first order dominate later ones in the expenditure distribution, with the reverse being true for the non market time distribution. In other words considering each argument on it's own would give strongly contrasting pictures of the changes in social welfare. The exception in the case of spending is the year 1995 which second order dominates 1990 and third order dominates 1985. Given that the univariate results run (for the most part) in opposite directions the lack of bivariate dominance results is not surprising. There is little indication of increased welfare for this cohort; second order dominance, however, is establish for 1995 over 1990, and for 1980 over 1975.

Table 4.5 report the descriptive statistics for households with a mean date-of-birth between 1929 and 1940. Mean real spending grows over the period whilst it variance also grows but not year-on-year: the variance is lower in 1980 than 1975 for example

and in 1995 compared to 1990. Non labour market time increases over the period and the variance drops.

Table 4.5: Descriptive statistics, households with mean adult d.o.b 1930 to 1939.

	$\tilde{x}^h$				$-t^h$				n
	Mean	Std.Dev	Min	Max	Mean	Std.Dev	Min	Max	
75	219.18	126.78	54.25	2483.55	-68.73	35.90	-204	0	1516
80	229.02	123.53	55.52	1323.36	-60.24	32.25	-164	0	1016
85	249.86	163.20	33.58	1963.46	-44.39	29.71	-152	0	849
90	262.64	202.94	48.76	2060.69	-33.51	27.42	-136	0	836
95	266.12	195.60	46.81	1952.59	-16.12	22.80	-110	0	880

The univariate dominance results reported in table 4.6 for non labour market time are clear cut with first order dominance established for every year over preceding ones. There is less of a patterns in the real expenditure (marginal) distribution. The bivariate results in the third block in table 4.6 follow the univariate ones in this case with first order dominance established for the three comparisons for which first order dominance in both the univariate distributions is established.

Table 4.6: Dominance results, households with mean adult d.o.b.1930 to 1939.

	$\psi(\tilde{x}^h)$					$\psi(-t^h)$					$\psi(\tilde{x}^h, -t^h)$				
	75	80	85	90	95	75	80	85	90	95	75	80	85	90	95
75															
80	$h_1$					$h_1$					$H_1$				
85						$h_1$	$h_1$								
90			$h_1$			$h_1$	$h_1$	$h_1$					$H_1$		
95			$h_1$			$h_1$	$h_1$	$h_1$	$h_1$				$H_1$		

The next date-of-birth cohort is made up of households with mean date-of-birth between 1939 and 1950. Descriptive statistics for this subsample are reported in table 4.7. This shows increase mean real expenditure for this cohort year-on-year throughout the period and increase inequality with the now typical exception of 1995 in which the variance of real spending fell compared to 1990. Mean non labour market time falls to begin with but then increases and its variance follows a similar pattern.

The univariate results in table 4.8 show a broadly similar pattern for both real spending and non market time, with later years generally dominating. An exception is 1995 in the spending distribution. Interestingly in the real spending distribution 1990 second order dominates 1995, whilst 1995 dominate 1990 in the non market time

Table 4.7: Descriptive statistics, households with mean adult d.o.b 1940 to 1949.

	$\tilde{x}^h$				$-t^h$				n
	Mean	Std.Dev	Min	Max	Mean	Std.Dev	Min	Max	
75	208.02	113.20	57.50	1625.56	-57.94	35.94	-270	0	1631
80	223.94	124.21	29.17	1531.69	-61.13	38.30	-236	0	1856
85	246.07	157.79	10.67	2096.67	-56.19	35.73	-207	0	1572
90	287.27	201.06	40.09	2866.13	-52.16	32.77	-162	0	1169
95	293.84	189.29	32.69	1808.40	-36.48	30.78	-138	0	903

distribution. Despite this first order dominance is established for 1995 over 1990 in the bivariate distribution. In general, later years first order dominate in the joint distribution up until 1990 with more mixed results for 1995. 1980 only second order dominates 1975 however. Note that the fact that 1995 first order dominates 1990, and 1990 first order dominates all 1980 and 1985 implies that if social preferences are transitive then 1995 dominates these years as well. This provides reasonable evidence of increased welfare for this group.

Table 4.8: Dominance results, households with mean adult d.o.b 1940 to 1949.

	$\psi(\tilde{x}^h)$					$\psi(-t^h)$					$\psi(\tilde{x}^h, -t^h)$				
	75	80	85	90	95	75	80	85	90	95	75	80	85	90	95
75						$h_1$					$H_2$				
80	$h_1$						$h_1$				$H_1$	$H_1$			
85	$h_1$	$h_1$				$h_1$	$h_1$				$H_1$	$H_1$	$H_1$		
90	$h_1$	$h_1$	$h_1$		$h_2$	$h_1$	$h_1$				$H_1$	$H_1$	$H_1$		
95	$h_1$					$h_1$	$h_1$	$h_1$	$h_1$		$H_1$				$H_1$

The final set of results are for cohorts born after 1949 (tables 4.9, and 4.10). Mean real spending increases throughout the period and there is also an increase in non market time. The variance for both covariates generally increase although not year-on-year.

Table 4.9: Descriptive statistics, households with mean adult d.o.b. 1950 and after.

	$\tilde{x}^h$				$-t^h$				n
	Mean	Std.Dev	Min	Max	Mean	Std.Dev	Min	Max	
75	212.96	104.15	70.00	838.52	-56.58	30.77	-197	0	515
80	221.36	121.62	39.81	1352.86	-49.72	30.80	-240	0	1180
85	231.47	152.78	37.84	2909.97	-48.41	36.06	-276	0	2102
90	265.19	205.47	21.67	5287.11	-48.66	34.38	-218	0	2982
95	285.17	180.60	28.43	1923.85	-47.15	33.82	-244	0	3517

Table 4.10: Dominance results, households with mean adult d.o.b. 1950 and after.

	$\psi(\tilde{x}^h)$					$\psi(-t^h)$					$\psi(\tilde{x}^h, -t^h)$				
	75	80	85	90	95	75	80	85	90	95	75	80	85	90	95
75		$h_2$	$h_2$									$H_{2(L)}$			
80			$h_2$			$h_1$							$H_2$		
85						$h_1$	$h_1$		$h_1$						
90				$h_1$		$h_1$							$H_2$		
95				$h_1$		$h_1$	$h_1$		$h_1$						$H_2$

The univariate results are mixed. In the real spending distribution all years first or second order dominate 1985, however in the non market time distribution 1985 dominates every other except for 1995. The bivariate results reflect this mixed picture with only second order dominance established for four comparisons out of ten (and only for functions drawn from  $\Psi^{++}$  for dominance of 1975 over 1980). Again transitivity of social preferences implies that 1995 second order dominates 1990 and the 1975 second order dominates 1985. This give weak evidence of decreasing welfare for this cohort in the earlier years and increasing welfare between 1990 and 1995.

## 5. Conclusions

This paper has extended the test procedures in Anderson (1996) to bivariate distributions. These tests were applied to UK data on real equivalised household spending and non labour market time. It was shown that it was possible to establish dominance of various orders using these techniques. It is also shown that considering each of the covariates in isolation may sometimes give strongly contrasting evidence on the changes in social welfare over time and that it may therefore be important to adopt the multivariate approach. Further, it was shown that even when the null of no dominance could not be rejected in one or other marginal distribution, dominance of various order could be established with respect to the joint distribution. The empirical results indicate that for the population overall, social welfare increased towards the end of the period with 1995 first order dominating 1975, 1985 and 1990 indicating unanimous ranking by all functions increasing in these argument. There is also evidence of increased social welfare between 1975 and 1980 for concave functions. Results by date-of-birth cohort indicate that most of the increases in welfare were felt by the 1939 to 1950 cohort. The youngest cohort (born in 1950 and after) show some indications of reduced welfare (for concave utility functions) in the earlier years but a gain in 1995 over 1985.

## References

- [1] Anderson, G. (1996), "Nonparametric tests of stochastic dominance in income distributions", *Econometrica*, **64**, 1183-1193.
- [2] Atkinson, A.B. and F. Bourguignon, (1982), "The comparison of multi-dimensional distributions of economic status", *Review of Economic Studies*, **XLIX**, 183-201.
- [3] Bishop, J.A., Chakarborti, S and P. D. Thistle (1989), "Asymptotically distribution-free statistical inference for generalised Lorenz curves," *Review of Economics and Statistics*, **71**, 725-727.
- [4] Blundell, R.W and A. Lewbel (1991), "The informational content of equivalence scales", *Journal of Econometrics*, **50**, 49-58.
- [5] Hadar, J. and W.R. Russell (1974), "Stochastic dominance criteria in choice under uncertainty", in M.S. Balch, D.L. McFadden and S.Y. Wu (eds.) *Essays on Economic Behaviour Under Uncertainty*, North-Holland: Amsterdam.
- [6] Harrison, A., (1982), "A tale of two distributions", *Review of Economic Studies*, **48**, 621-631.
- [7] Harsanyi, J.C. (1955), "Cardinal welfare, individualistic ethics, and interpersonal comparisons of utility", *Journal of Political Economy*, **63**, 621-631.
- [8] Hicks, J. (1940), "The valuation of the social income", *Economica*, **7**, 105-124.
- [9] Ibbott, P. (1998), "Intergenerational changes in the distribution of consumption", mimeo.
- [10] Kendall, M.G. and A. Stewart (1979), *The Advanced Theory of Statistics*, London: Griffin.
- [11] Levy, H. and J. Paroush (1974) "Toward multivariate efficiency criteria", *Journal of Economic Theory*, **7**, 129-142.
- [12] Magnus, J. R. and H. Neudecker, (1988), *Matrix Differential Calculus*, New York: Wiley.
- [13] Neary, J.P. and K.W.S. Roberts, (1980), "The theory of household behaviour under rationing", *European Economic Review*, **13**, 25-42.
- [14] Rothbarth, E. (1941), "The measurement of changes in real income under conditions of rationing", *Review of Economic Studies*, **8**, 100-107.
- [15] Sen, A., (1979a), "The welfare basis of real income comparisons", *Journal of Economic Literature*, **17**, 1-45.
- [16] Sen, A. (1979b), "Equality of what?", the Tanner lecture on Human Values, Stanford University, reprinted in Sen, A. (1982), *Choice Welfare and Measurement*, Cambridge, M.A.: Harvard University Press
- [17] Silverman, B.W. (1986), *Density Estimation for Statistics and Data Analysis*, *Monographs on Statistics and Applied Probability*, Chapman & Hall: London.
- [18] Stoline, M.R. and H.A. Ury (1979), "Tables of the Studentised Maximum Modulus Distribution and an application to multiple comparisons among means", *Technometrics*, **21**, 87-93.
- [19] Ulph, D.T. (1978), "On labour supply and the measurement of inequality", *Journal of Economic Theory*, **19**, 492-512.